

8FCX51

8Ω**Coaxials - 8.0 Inches**

- 500 W continuous program power capacity
- 100° nominal coverage
- 70 - 18000 Hz response
- 96 dB sensitivity
- 20.1 mm (0.79") HF unit exit diameter

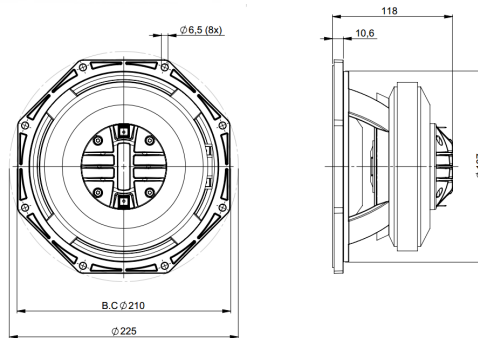

8FCX51

Coaxials- 8.0 Inches

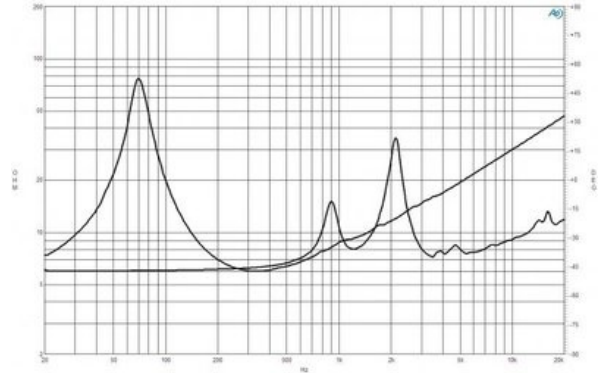
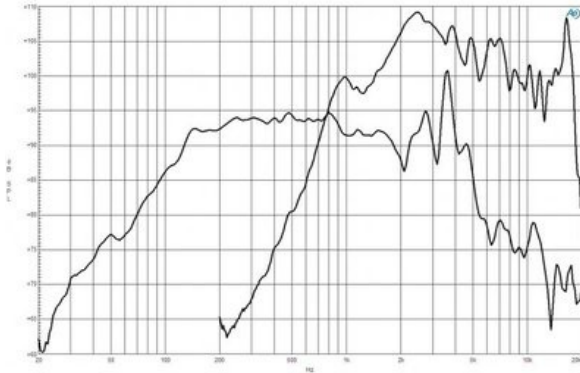

SPECIFICATIONS

Nominal Diameter	210 mm (8.0 in)
Nominal Impedance	8 Ω
Minimum Impedance LF	6.0 Ω
Minimum Impedance HF	7.0 Ω
Frequency Range	69 - 18000 Hz
Dispersion Angle ¹	100 °
Magnet Material	Ceramic

SPECIFICATIONS LF UNIT

LF Sensitivity ²	96.0 dB
LF Nominal Power Handling ³	250 W
LF Continuous Power Handling ⁴	500 W
LF Voice Coil Diameter	51 mm (2.0 in)
LF Winding Material	Aluminium
LF Flux Density	1.0 T
Former Material	Glass Fibre
Winding Depth	17.5 mm (0.69 in)
Magnetic Gap Depth	8.0 mm (0.31 in)

SPECIFICATIONS HF UNIT

HF Sensitivity ⁵	104.0 dB
HF Nominal Power Handling ⁶	50 W
HF Continuous Power Handling ⁷	100 W
HF Voice Coil Diameter	44 mm (1.7 in)
HF Winding Material	Aluminium
HF Flux Density	1.8 T
Diaphragm Material	Polyimide
Recommended Crossover ⁸	1.8 kHz
Inductance	0.11 mH

PARAMETERS

Resonance Frequency	69 Hz
Re	4.9 Ω
Qes	0.36
Qms	6.3
Qts	0.34
Vas	16.0 dm ³ (0.56 ft ³)
Sd	220.0 cm ² (34.1 in ²)
η _o	1.4 %
X _{max}	6.5 mm
X _{var}	6.0 mm
M _{ms}	22.0 g
Bl	11.5 Txm
Le	0.9 mH
EBP	191 Hz

MOUNTING AND SHIPPING INFO

Overall Diameter	225 mm (8.8 in)
Bolt Circle Diameter	210 mm (8.3 in)
Baffle Cutout Diameter	187 mm (7.4 in)
Depth	118 mm (4.64 in)
Flange and Gasket Thickness	10 mm (0.37 in)
Net Weight	5.1 kg (11.2 lb)
Shipping Units	1
Shipping Weight	5.7 kg (12.57 lb)
Shipping Box	295x314x175 mm (11.61x12.36x6.89 in)

SERVICE KIT

Service Kit LF	RCK008FCX518
Replacement diaphragm	MMD4008

- Included by -6 dB down points.
- Applied RMS Voltage is set to 2.83V.
- 2 hours test made with continuous pink noise signal (6 dB crest factor) within the range Fs-10Fs. Power calculated on rated minimum impedance. Loudspeaker in free air.
- Power on Continuous Program is defined as 3 dB greater than the Nominal rating.
- Applied RMS Voltage is set to 2.83V.
- 2 hour test made with continuous pink noise signal (6 dB crest factor) within the range from the recommended crossover frequency to 20 kHz. Power calculated on rated minimum impedance. Loudspeaker in free air.
- Power on Continuous Program is defined as 3 dB greater than the Nominal rating.
- 12 dB/oct. or higher slope high-pass filter.