

2NDF26

8Ω**LF Drivers - 2.0 Inches**

- 60 W continuous program power capacity
- 26 mm (1 in) aluminum voice coil
- 165 - 20000 Hz response
- 84 dB sensitivity
- Neodymium magnet allows a very light yet powerful motor assembly

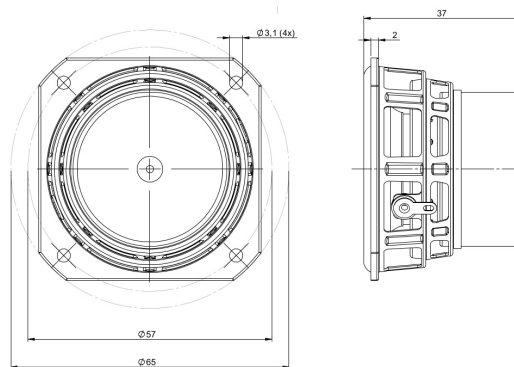

Neodymium magnet allows a very light yet powerful motor assembly
OEM Quantities only

2NDF26

LF Drivers- 2.0 Inches

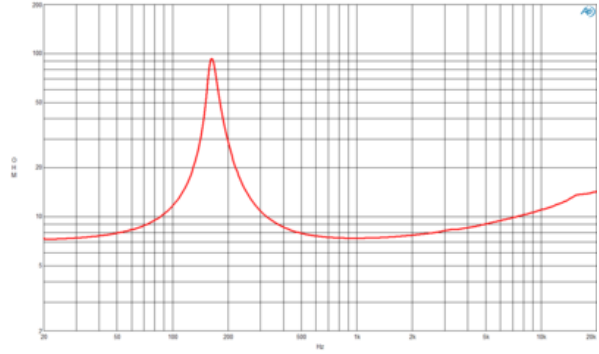
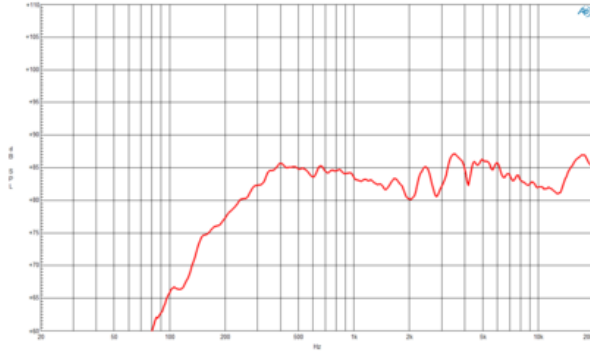

SPECIFICATIONS

Nominal Diameter	50 mm (2.0 in)
Nominal Impedance	8 Ω
Minimum Impedance	7.5 Ω
Nominal Power Handling ¹	30 W
Continuous Power Handling ²	60 W
Sensitivity ³	84.0 dB
Frequency Range	165 - 20000 Hz
Voice Coil Diameter	26 mm (1.0 in)
Winding Material	Aluminium
Former Material	Nomex
Winding Depth	7.0 mm (0.28 in)
Magnetic Gap Depth	3.5 mm (0.14 in)
Flux Density	1.3 T

DESIGN

Surround Shape	Roll
Cone Shape	Radial
Magnet Material	Neodymium Inside Slug
Spider	Single
Pole Design	Straight Pole
Woofer Cone Treatment	None

PARAMETERS⁴

Resonance Frequency	165 Hz
Re	7.0 Ω
Qes	0.59
Qms	10.3
Qts	0.56
Vas	0.2 dm ³ (0.01 ft ³)
Sd	15.0 cm ² (2.33 in ²)
η _o	0.14 %
Xmax	2.6 mm
Xvar	3.1 mm
Mms	1.4 g
Bl	4.1 Txm
Le	0.16 mH
EBP	279 Hz

MOUNTING AND SHIPPING INFO

Overall Diameter	65 mm (2.56 in)
Bolt Circle Diameter	57 mm (2.24 in)
Baffle Cutout Diameter	48.0 mm (1.89 in)
Depth	37 mm (1.46 in)
Flange and Gasket Thickness	2 mm (0.08 in)
Air Volume Occupied by Driver	0.1 dm ³ (0.0 ft ³)
Net Weight	0.17 kg (0.37 lb)
Shipping Units	100
Shipping Weight	18.3 kg (40.34 lb)
Shipping Box	411x404x225 mm (16.18x15.91x8.86 in)

SERVICE KIT

-

1. 2 hours test made with continuous pink noise signal within the range Fs-10Fs. Power calculated on rated nominal impedance. Loudspeaker in free air.
2. Power on Continuous Program is defined as 3 dB greater than the Nominal rating.
3. Applied RMS Voltage is set to 2.83 V for 8 ohms Nominal Impedance.
4. Thiele-Small parameters are measured after a high level 20 Hz sine wave preconditioning test.